

# RUBBER PICKING FINGERS

## TECHNICAL SPECIFICATIONS

ELASTOMER BASE	Natural Rubber
COLOR	Black - Red - Green
Strength Shore A	50 to 80 points
Temperature	-50°C to 90°C
MECHANICAL PROPERTIES	High tension resistance, elongation and flexibility Abrasive resistance. High resistance, Low low deformation. None or minimum water absorbance.
CHEMICAL PROPERTIES	Resistance to acids and salty substances
CAUTIONS	Do not use with fuels, oils and derivatives.
GUARANTEES	Resistance to hot water and vapor at high pressure

**HERNOL** is offering these picking fingers for all type of plucking machines. We fabricate with natural Rubber and the highest quality compounds to obtain a durable and dependable product with a minimum wear and discharge of its components.

We are producing various designs with different strength to allow great flexibility to not damage the skin of the bird. Compatible to many machines and adapting to needs of your processing plants.

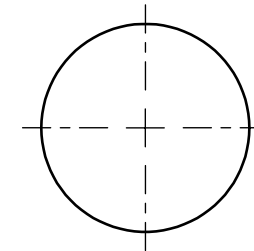
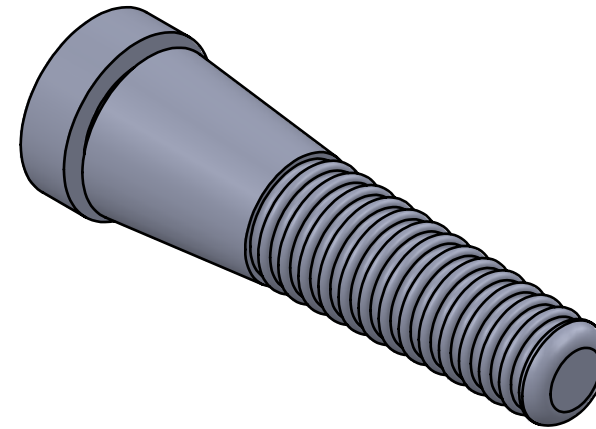
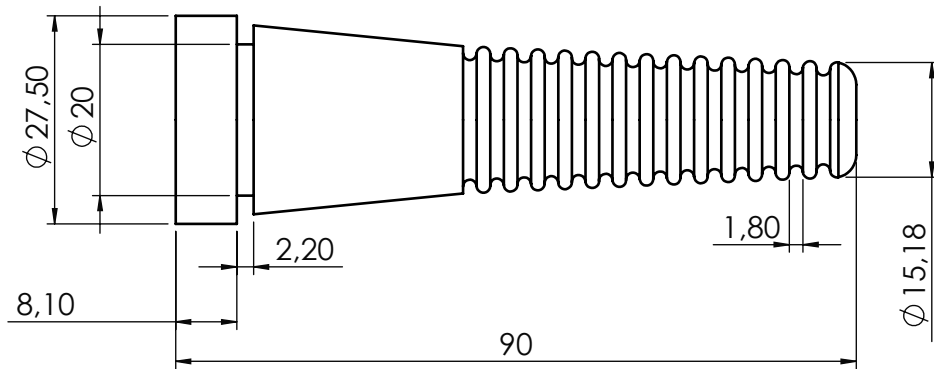

SI NO SE INDICA LO CONTRARIO:  
 LAS COTAS SE EXPRESAN EN MM  
 TOLERANCIAS:  
 LINEAL: 0.02 mm  
 ANGULAR: 0.2°

	NOMBRE	FIRMA	FECHA	<b>INDUSTRIAS HERNOL S.A.</b>
DIBUJO.	Leonardo Vlizcaya		31-03-2015	
VERIFICA.	Oscar Pineda Daza		31-03-2015	
APROBACIÓN.	Victor Gonzalez		31-03-2015	
TRATAMIENTO TÉRMICO:	N.A.	MATERIAL:	CAUCHO NATURAL	PROYECTO:
DUREZA:	50 Shore A	CANTIDAD:	N.A.	DEDOS DEPLUMADORES DE AVES
ACABADO SUPERFICIAL:	N.A.	PESO:	29 Gramos	PIEZA:
				IP-001
				ESCALA: 1:1
				HOJA 1 DE 1

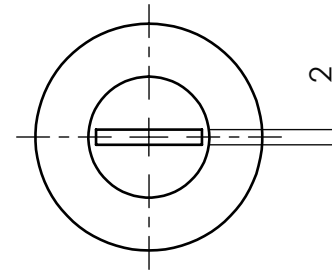
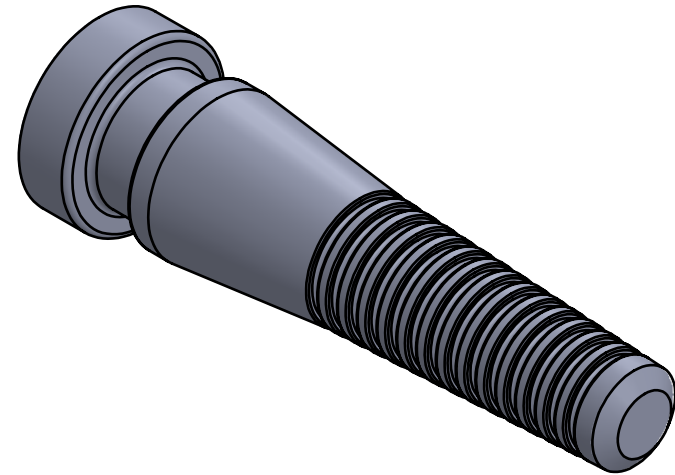
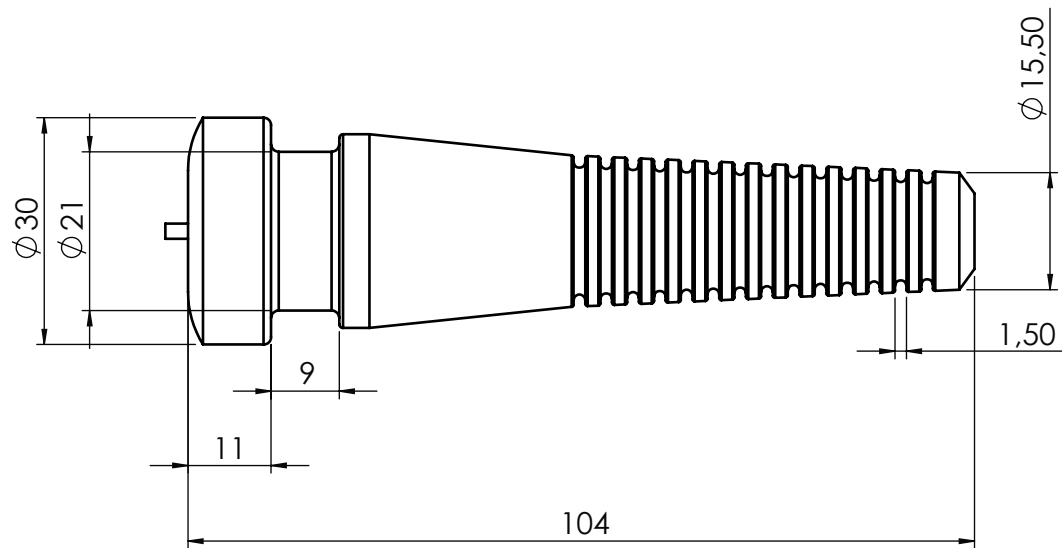

SI NO SE INDICA LO CONTRARIO:  
 LAS COTAS SE EXPRESAN EN MM  
 TOLERANCIAS:  
 LINEAL: 0.02 mm  
 ANGULAR: 0.2°

	NOMBRE	FIRMA	FECHA	INDUSTRIAS HERNOL S.A.
DIBUJO.	Leonardo Vlizcaya		31-03-2015	
VERIFICA.	Oscar Pineda Daza		31-03-2015	PROYECTO:
APROBACIÓN.	Victor Gonzalez		31-03-2015	DEDO DESPLUMADORES DE AVES
TRATAMIENTO TÉRMICO:	N.A.	MATERIAL:	CAUCHO NATURAL	PIEZA:
DUREZA:	50 Shore - A	CANTIDAD:	N.A.	IP-002
ACABADO SUPERFICIAL:	N.A.	PESO:	40 gramos	ESCALA: 1:1
				HOJA 1 DE 1

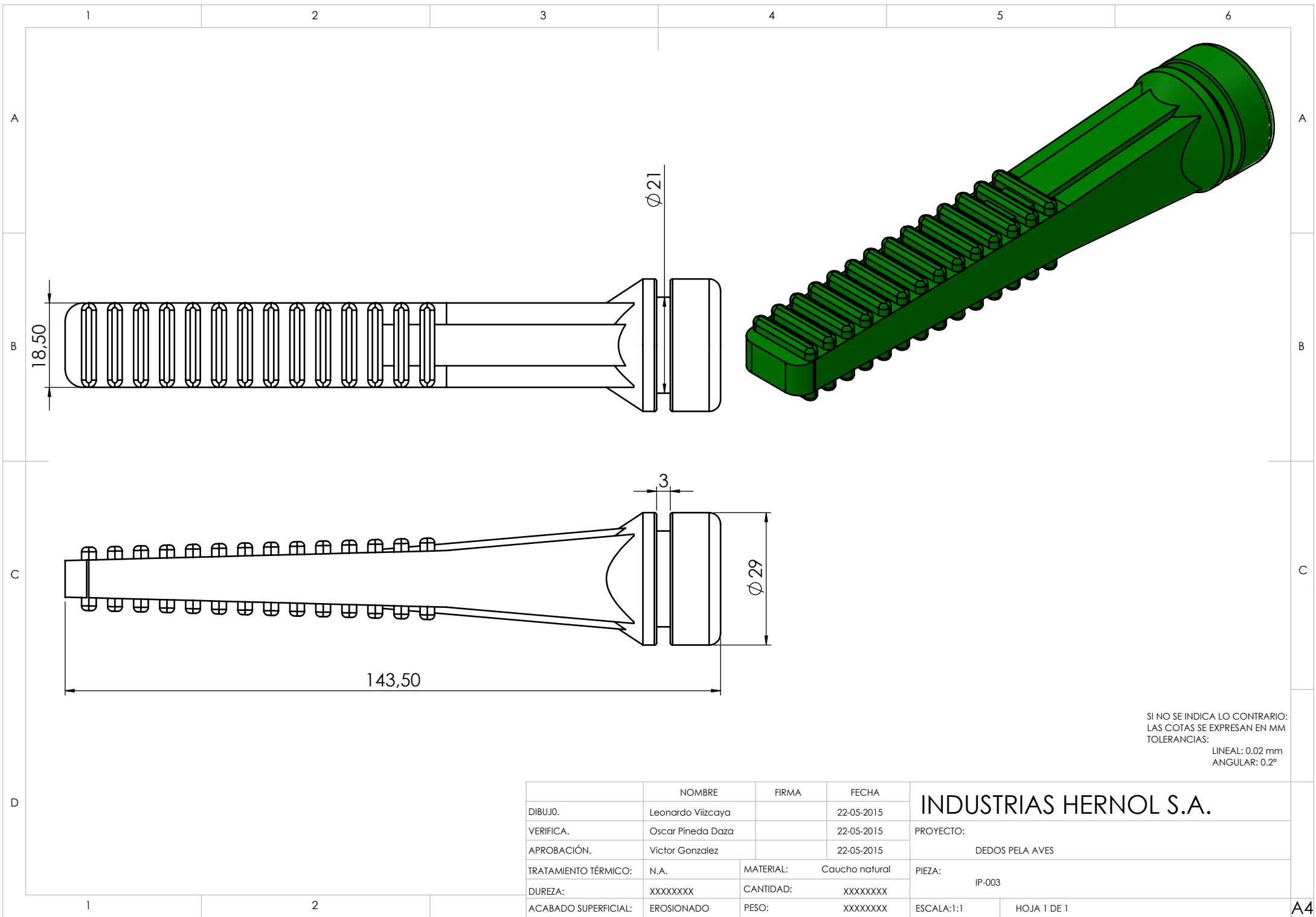

SI NO SE INDICA LO CONTRARIO:  
 LAS COTAS SE EXPRESAN EN MM  
 TOLERANCIAS:  
 LINEAL: 0.02 mm  
 ANGULAR: 0.2°

	NOMBRE	FIRMA	FECHA	INDUSTRIAS HERNOL S.A.
DIBUJO.	Leonardo Vlizcaya		22-05-2015	
VERIFICA.	Oscar Pineda Daza		22-05-2015	PROYECTO:
APROBACIÓN.	Victor Gonzalez		22-05-2015	DEDOS PELA AVES
TRATAMIENTO TÉRMICO:	N.A.	MATERIAL:	Caucho natural	PIEZA:
DUREZA:	XXXXXXX	CANTIDAD:	XXXXXXX	IP-003
ACABADO SUPERFICIAL:	EROSIONADO	PESO:	XXXXXXX	ESCALA:1:1
				HOJA 1 DE 1